

GVM

GREAT VIDEO MAKER

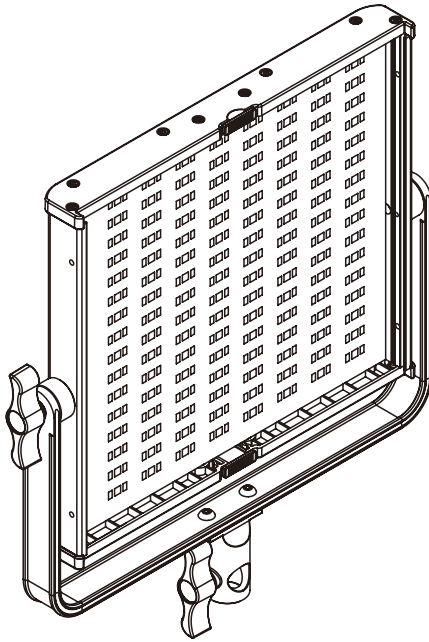

GVM-50RS

Buku Manual

Pengenalan Produk

Welcome to "GVM-50RS". This product is specially designed for senior photography enthusiasts. The product is suitable for live / outdoor / studio photography, and also for youtube video shooting. The main features of the product are:

- ① step-less adjustable RGB color and dual color temperature feature, color range 3200K ~ 5600k, with 384 LED bulbs, which is helpful to restore and enrich the color of objects and provide you with natural and vivid shooting effect.
- ② App intelligent control system, which can be controlled by your intelligent mobile device.
- ③ LCD screen display and stable system, which can support 360 ° rotation and effectively control the light Line. You can also install folding and external soft light board to avoid redundant light and make the light softer. You can customize the control of fill light, so that you can easily shoot the desired results.

We believe that once using our product correctly, you can make huge progress when shooting. Before using the product, you are strongly recommended to read the instructions below carefully.

Spesifikasi

- ◆ Brand : GVM
- ◆ Name : photography light
- ◆ Type : photography fill light
- ◆ Number : GVM-50RS
- ◆ Material : aluminum alloy
- ◆ Number of light beads : 384
- ◆ Color-rendering Index : ≥ 97
- ◆ Color Temperature : 3200K---5600K
- ◆ Luminance : 6500lux/0.5m, 1600lux/1m
- ◆ Function/Characteristics : RGB, APP, joint control, high color-rendering index light beads
- ◆ Power : 50W
- ◆ Power Supply Mode : DC input & Battery
- ◆ Voltage : AC:100-240V
- ◆ Power specification : DC15V/4A
- ◆ Battery Capacity : 7.4V-4400mAh*2 (to be purchased separately)
- ◆ Weight : 1.87KG
- ◆ Size (mm) : 310x320x55
- ◆ Heat Dissipation : natural way
- ◆ Brightness adjusting : stepless adjustment
- ◆ Color Temperature adjusting : stepless adjustment
- ◆ Origin : Huizhou, China

Bagian

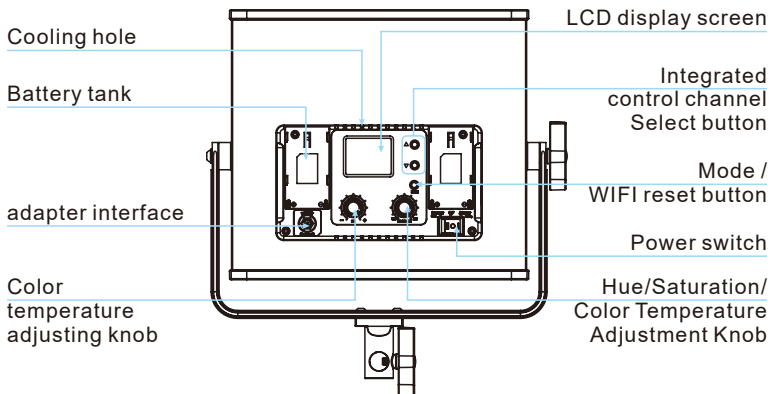
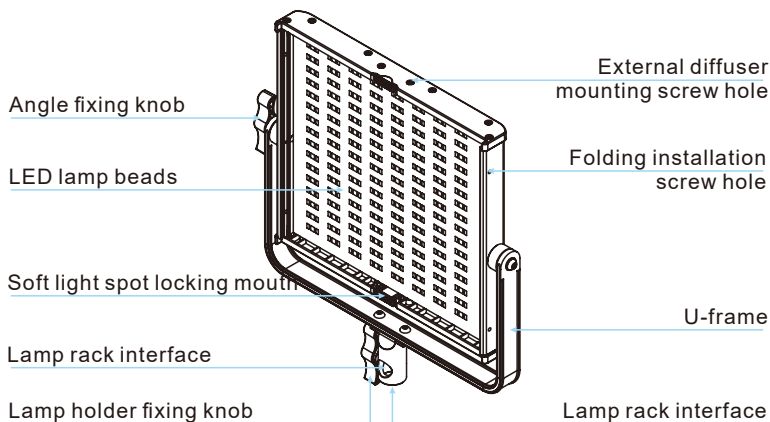

Cara Memasang

- 1 The lamp can be installed and fixed on the bracket by rotating the knob clockwise, and unloaded by rotating in the counterclockwise direction.

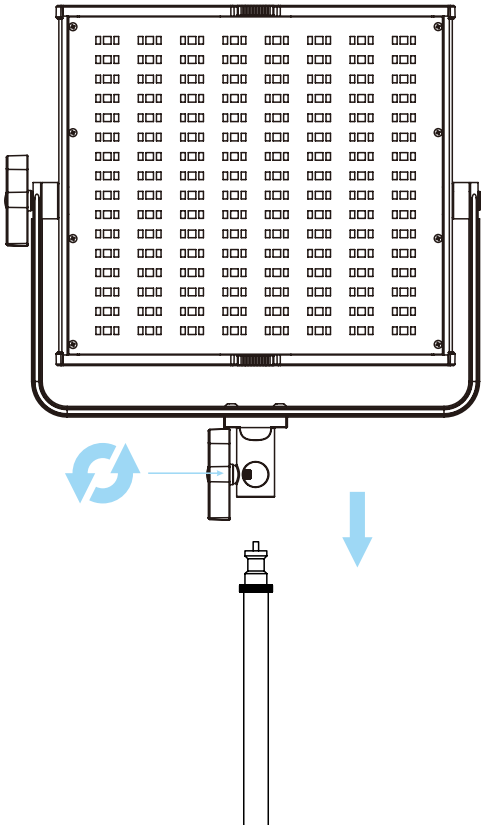

- 2** Insert the Subdued light board from the top of the light panel.

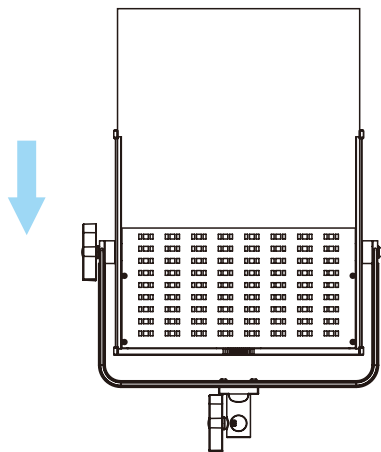

- 3** Loosen the adjustment knobs on both sides of the U-bracket, adjust the angle of the panel you need, and then tighten the adjustment knobs on both sides of the U-bracket.

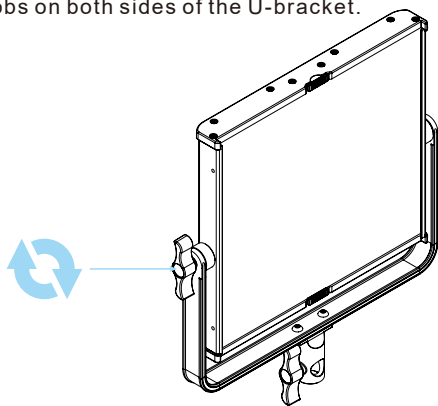

4 There are two power supply modes to choose.

- ① connect the power cord and adapter for power supply.
- ② purchase two other suitable lithium batteries and use them for power supply. (both battery cells must be plugged in to power)

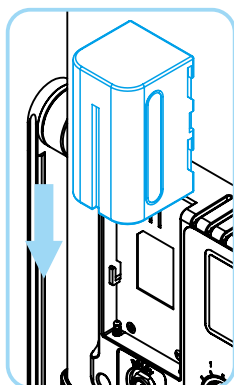

**Battery
installation slot**
(battery lead)

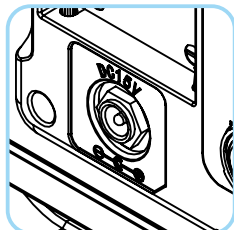

Adapter interface

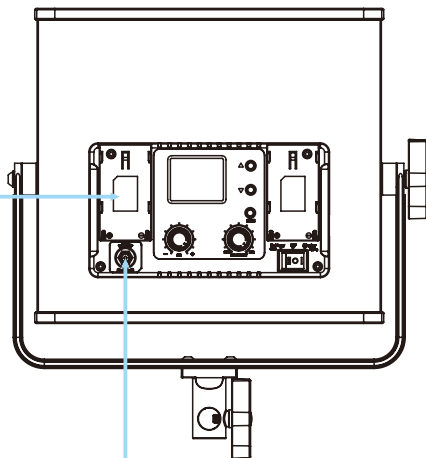

Pemasangan Aksesoris

Light control folding (aksesoris dijual terpisah)

You can buy a set of light control folding to control the angle of light.

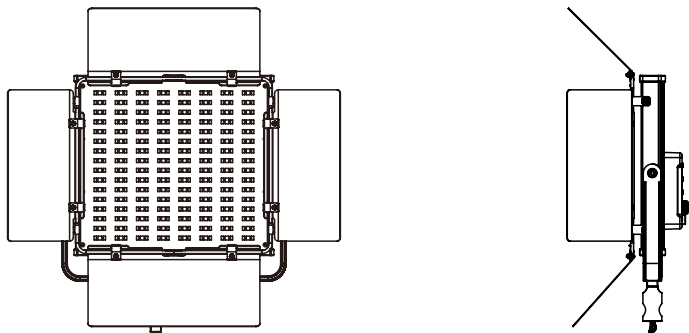

Install the hinge: align the front mounting hole with the screw hole of the hinge, and lock the door latch with the screw.

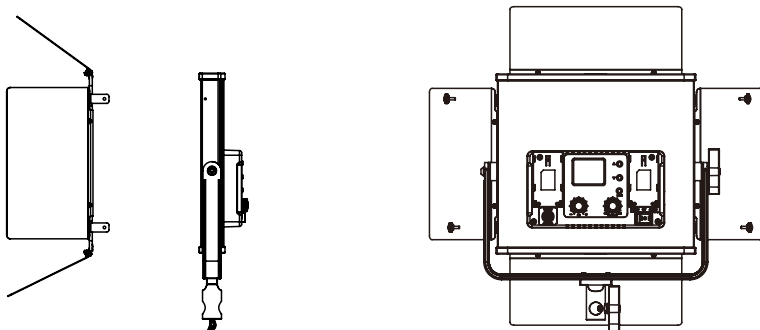

External soft-board (aksesoris dijual terpisah)

Make the light softer and achieve the effect of soft light box.

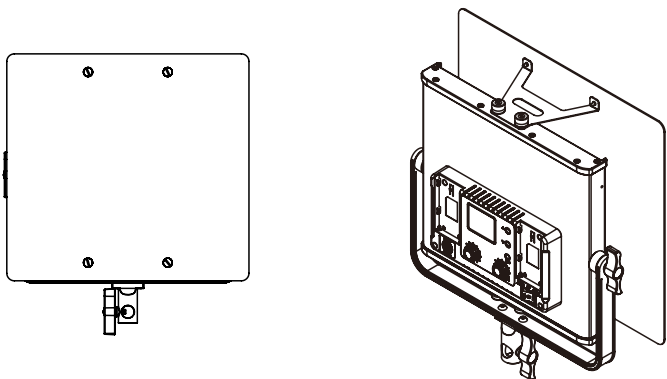

Install the external Diffuser: install the diffuser support frame to the lamp, align the diffuser with the screw hole, and lock the diffuser with the screw.

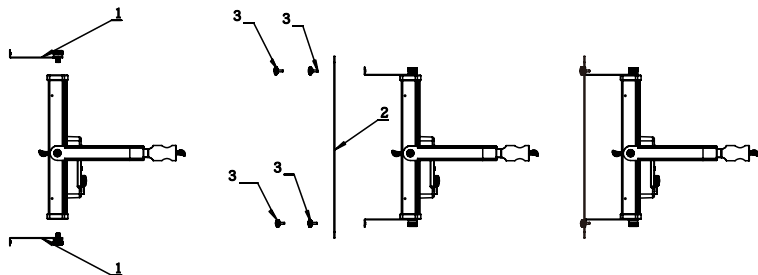

Fungsi Bagian

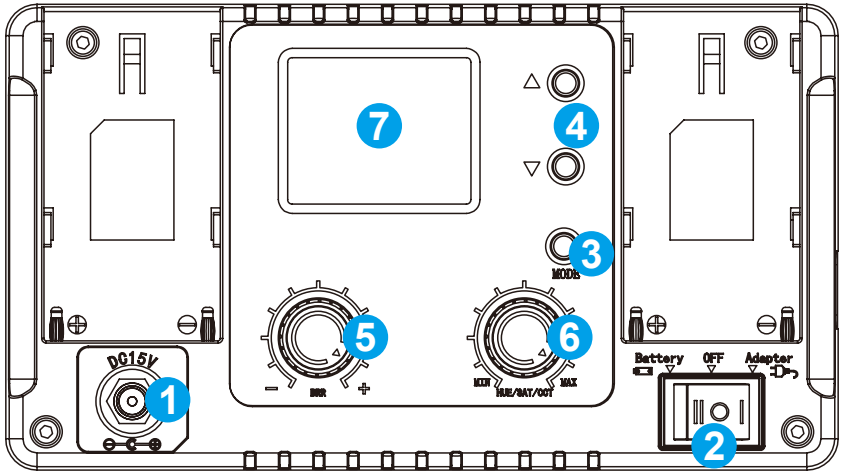

- 1** DC15V power input interface
- 2** Power switch
- 3** Mode button / WIFI reset button: Modes include host mode and slave mode; WIFI username and password reset button
- 4** Channel addition and subtraction key: adjust channel (0~11)
- 5** Brightness adjustment button: adjust the brightness (10%~99%)
- 6** Hue / Saturation / Color Temperature Adjustment Knob: Adjust Hue / Saturation / Color Temperature, Hue RGB, Saturation (10%~99%) Color Temperature Range (3200K~5600K)
- 7** LCD screen: display brightness, hue, saturation, color temperature, mode, channel value and other data

Cara Menggunakan

① Mode selection:

There are two kinds of more which are host mode and slave mode, switching through mode button (automatically as host mode when switch on the machine). In host mode, it is able adjust lightness, color temperature and channel value, and it is also able to connect APP, and control the parameters through APP. While in the slave mode, it is only able to set channel value, rather than lightness and color temperature.

② Channel adjustment:

Set channel value using channel addition and subtraction key, ranging from 0 to 11.

③ Brightness adjustment:

In the host mode, adjust lightness through the knob or APP, ranging from 10% to 99%.

④ Adjust the hue:

In the master mode, the hue can be adjusted by the hue / saturation / color temperature adjustment knob or APP, and the range is RGB.

⑤ Adjusting the saturation:

In the master mode, the saturation can be adjusted by the Hue / Saturation / Color Temperature Adjustment knob or APP, ranging from 10% to 99%.

⑥ Color temperature adjustment:

In the master mode, the color temperature can be adjusted by the hue / saturation / color temperature adjustment knob or APP, ranging from 3200K to 5600K.

⑦ Color temperature adjustment:

Prepare two or more photography lights, set on as host mode and the other slave mode, and set a same channel value, in this way, it is able to control the lightness hue and saturation and color temperature of slave machine through adjusting the knob of the host machine. Moreover, it is also able to connect the host machine and APP, and then use the APP the control the slave machines.

Cara Menggunakan Aplikasi

Switch the photography lamp to the host mode (*the default host mode when the phone is turned on*). The mobile phone opens the "GVM Easily" app software (*at the same time, turn on the WiFi function of the mobile phone*). In the main menu of the app interface - switch device - - Select the device type as "single and double color photography lamp". Then in the main menu of the app interface - Settings - select "switch WiFi". In the WiFi list, select connect RGB Lantern WiFi (*WiFi initial user name: GVM - LED, password: GVM - admin*), after the mobile phone displays "connected GVM - LED", return to the APP main interface, when the APP main interface displays "RGB LED light (*successfully connected*)", you can control the brightness,Hue,saturation, color temperature, channel, on / off and other control keys on the APP to control the brightness, ,Hue,saturation, color temperature, channel value and switch of the host. If there is a slave, the slave and the host are controlled by the APP synchronously The master / slave online mode is the same as "page 9, 6. Online control (*joint control between lamps and lanterns*)")"

main menu

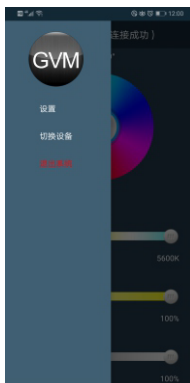
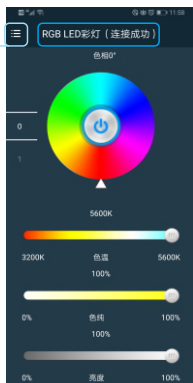

WiFi username and password resetting

It is able to reset the WiFi username and password if long press the WiFi reset button for over 5 seconds. After resetting, the username and the password will return to the initial (*WiFi username: GVM_LED, WiFi password: gvm_admin*).

Catatan Keselamatan

- ① Please use the matching power adapter or lithium battery with the same specification to power the product. Do not use power adapter with different output voltage parameters.
- ② The product is not waterproof, please use it in rainproof environment.
- ③ The product is not anti-corrosion, therefore do not let the product touch any corrosive liquid.
- ④ When using the product, make sure the product is put firmly and prevent from falling and damage.
- ⑤ If the product will not be used for a long time, please switch off the power to reduce energy loss.

Troubleshooting

Phenomenon	Check the product	Troubleshooting
the switch indicator does not light up	① check the matching power adapter indicator light up or not.	make sure the adapter is well contacted with the power plug
	② when using lithium battery, make sure there's no "low power" protection.	charge the battery before using it
the knob of lightness and color temperature are out of control	check if the mode were set as slave mode, lightness and color temperature of the products cannot be controlled in slave mode	press the "mode" button for once, switch the mode from slave mode to host mode
the screen and the light are off when the product is in the state of power-on	check if the product is "switch off" because of the APP of mobile phone.	press the "ON/OFF" button once again

Catatan Penting

1. Before using this product, please read the instructions carefully and make sure use the product correctly. If you don't obey the instructions and warnings, you maybe cause harm to yourself and the people around, or even damage the product and other things around.
2. Once you use the product, it means you have already read the disclaimer and the warnings carefully, understanding and agreeing with all the items, and promise to take responsibility of any consequences of using the product.

Perawatan

Do not put the product in highly humid, strong electromagnetic field, direct sunlight, high temperature environment. If not use the product for a long time, disconnect the power and take out the battery.

Clean: Before clean, disconnect the power plug. And use wet cloth rather than any detergent or soluble liquid, avoiding of damaging the surface layer.

Power: Make sure the power is in the demanded range, not too high or too low. Correctly load the battery, in order not the damage to machine.

Repairing: If there is fault or performance degradation, do not unpack the shell by yourself, avoiding damage the machine and lose the right of maintenance. When there is fault, do not hesitate to contact us, and we will do our best to deal the problem.

Accessories: Please use the accessories provided by manufacturer and approved ones, in order to maximize the performance.

Guarantee: Do not modify the product, or you will lose the right of maintenance.